



ROHS, TS16949, ISO9001

CNT836P

GNSS/INS(UDR) Vehicle Integrated Navigation and
Positioning Module
Manual

Dec. 2022

Revision History

Version NO.	Version	Date
V.1	New	Dec. 2022

Disclaimer

This document only indicates the information of the products of Shenzhen Simple Technology Electronics Co., LTD without any transfer purposes, including has no transfer any patent, trademark, Copyright or ownership right or any rights or licenses under Company or any third party by implication, estoppel or other ways. We (Shenzhen Simple Technology Electronics Co., LTD) accepts no liability other than those stated in the terms and conditions of Sale of its products. Furthermore, regarding the sale and use of its products, Simple makes no any kinds of express or implied warranties including fitness for a particular purpose, marketability or liability for infringement of any patent, copyright or other intellectual property rights. If the connection or operation is not in accordance with the manual requirements, the company is exempt from liability. Simple perhaps make modifications to product specifications and descriptions at any time without prior notice. The products of our company may contain certain design defects or errors, which will be included in the corrigendum upon discovery, and may result in differences between the product and the published specifications. An updated erratum is available upon request.

目录

1. Product description.....	4
1.1 Overview.....	4
1.2 Main features.....	4
1.3 Application Fields.....	4
1.4 Technical Specifications.....	4
2. PINS Descriptions.....	7
2.1 Pins Definitions.....	7
2.2 PINS Descriptions.....	7
3. Hardware Interface Description.....	9
3.1 Antenna.....	9
3.2 Power Supply.....	9
3.3 UART.....	9
3.4 PPS.....	10
3.5 RST_N.....	10
3.6 GPIO.....	10
3.7 EXTINT.....	10
4. Firmware Default configuration.....	11
5. Module Installation and Initialization.....	12
5.1 Module installation instructions.....	12
5.2 Initialization Instructions.....	13
6. Electrical Characteristics.....	14
6.1 Absolute Maximum.....	14
6.2 Operating Conditions.....	14
6.3 Working Environment.....	15
7. Mechanical specifications.....	15
8. Hardware Integration Guide.....	16
8.1 Minimum reference design.....	16
8.2 Antenna Attentions.....	17
8.3 Power Supply Attentions:.....	19
8.4 Other Attentions.....	19
9. Production requirements.....	20



10. Packaging and Transportation.....20

 10.1 Packing.....21

 10.2 ESD Protection..... 21

11. Ordering Information.....22

1. Product description

1.1 Overview

The CNT836P, GNSS/INS (UDR) vehicle single frequency RTK integrated navigation and positioning module, can simultaneously support BDS B1, GPS L1 two frequency points. Builds in six-axis inertial device, adopts GNSS/INS integrated navigation and positioning technology, can provide high-precision vehicle positioning and navigation functions, including provide high-precision positioning for vehicles in tunnels, garages and other environments. CNT836P, of compact size, uses SMD pad, supports standard automatic process of taking and placing and reflow welding. It, as a high-performance integrated navigation positioning module, has the characteristics of high sensitivity, anti-interference, high performance, etc.

1.2 Main features

- GNSS/INS integrated navigation and positioning technology
- Support adaptive installation
- Support Beidou-3th satellites
- Support inertial hot start and rapid positioning of pure inertial environment
- size 16*12, compatible with mainstream module package design
- Industrial standard modules

1.3 Application Fields

The module is mainly used in the vehicle terminal required navigation function, supporting directly install on the terminal, such as vehicle positioning monitoring terminal and other high level integration navigation application fields.

1.4 Technical Specifications

Power Supply	
Voltage	3.0V - 3.6V
RF Input	
Frequency	BDS B1I, GPS L1C/A
Voltage Standing Wave Ratio	≤ 1.5
Input Impedance	50 Ω
Antenna gain	5 ~40dB
Physical Characteristics	
Size	16.0 x 12.2 x 2.4 (mm)
Input/Output Data Interface	
UART	LVTTTL level, default baud rate of 115200bps
GNSS Performance	
First positioning time ^[1]	Cold Start: $\leq 30s$ Hot Start: $\leq 1s$ Recapture: $\leq 1s$
Positioning Accuracy ^[2]	Single Point: 1.5m <hr/> RTK: 2.5cm+1ppm
Speed Measurement Accuracy ^[3]	0.1 m/s
Sensitivity ^[4]	Tracking: -162 DBM

Capture	-147 DBM
PPS Accuracy	50ns
Data Update Rate	MAX 10Hz
Navigation Data Format	NMEA 0183 V4.0
INS performance	GNSS signal loss 60S: $\leq 5\%$ driving distance ^[5]

[1] Test conditions: The available satellites are more than 6, and the signal strength of all satellites is not less than -130dBm.

[2] Test conditions: RMS, the number of satellites is greater than 6, 24-hour static positioning, and the signal strength of all satellites is not less than -130dBm.

[3] Testing conditions: RMS@30m/s

[4] Test conditions: LNA test with good performance for external use

[5] Test conditions: need to complete calibration, enter the integrated navigation mode

2. PINS Descriptions

2.1 Pins Definitions

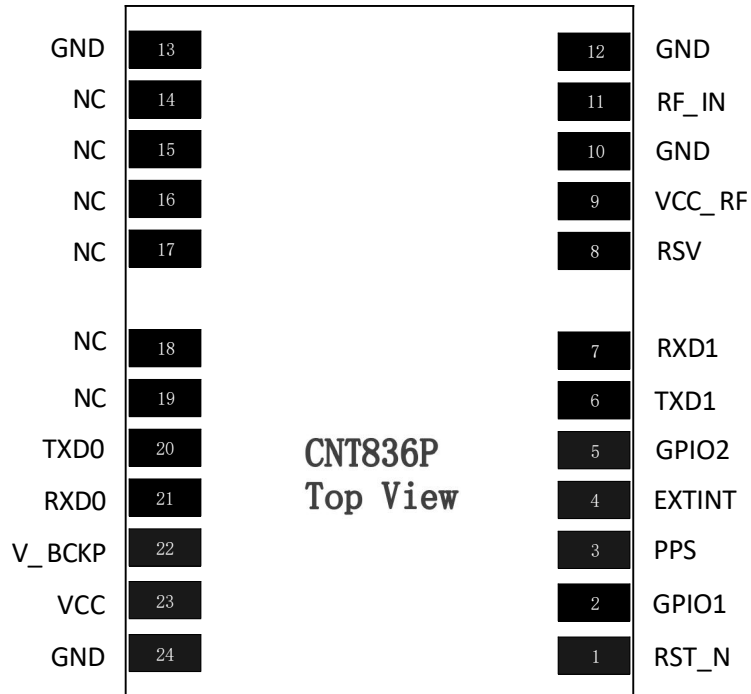

Figure 2-1 Definitions of the PINS

2.2 PINS Descriptions

9	VCC_RF	PWR	3.3 V + / - 10%	Antenna feed power (if not in use, be unconnected)
10	GND	PWR	- -	Ground
11	RF_IN	I	- -	RF input signal
12	GND	PWR	- -	Ground
13	GND	PWR	- -	Ground
14	NC	--	- -	Be unconnected
15	NC	--	- -	Be unconnected
16	NC	--	- -	Be unconnected
17	NC	--	- -	Be unconnected
18	NC	--	- -	Be unconnected
19	NC	--	- -	Be unconnected
20	TXD0	O	LVTTL	UART0, data send signal, FW update
21	RXD0	I	LVTTL	UART0, Data reception signal, FW update
22	V_BCKP	PWR	2.0 V -3.6 V	<p>RTC power supply, while powering the internal gyroscope, be connected.</p> <p>Power on no later than VCC, otherwise the gyroscope initialization will fail.</p> <p>Note: It is recommended to use external battery power, if no external battery, please connect this pin with the VCC.</p>
23	VCC	PWR	3.3 V + / - 10%	Main power supply
24	GND	PWR	- -	Ground

3. Hardware Interface Description

3.1 Antenna

The CNT836P module provides an antenna signal input interface (RF_IN) for external GNSS multi-mode active antenna or passive antenna. The internal interface adopts 50ohm impedance matching. In order to obtain better performance, it is recommended to reserve external impedance matching circuit

3.2 Power Supply

The CNT836P module provides two input power interfaces (VCC and V_BCKP) and one output power interface (VCC_RF). VCC is the main power supply of the module, and power the main IC in chip through the power conversion inside chip. V_BCKP is the backup power supply of the module, which can still supply power to the RTC circuit, gyroscope and backup RAM in the module when the main power is off, so as to realize the hot start function and shorten the positioning time. V_BCKP should not be powered on later than VCC, otherwise it will cause the gyroscope initialization failure. The VCC_RF can provide a feed to an external active antenna or an external LNA.

3.3 UART

The CNT836P module provides two sets of serial ports, namely UART0 (TXD0, RXD0) and UART1 (TXD1, RXD1). UART0 is open to users by default, supports data transmission and firmware upgrade functions, and with the LVTTTL level as its the input/output signal type. The default baud rate is 115200bps, the maximum can be set to 230400bps, the serial port baud rate can be configured by the user. When designing the product make sure UART0 is connected to a PC or external processor for firmware upgrades. Do not pull down the resistance on the serial port, and do not set the pin of the main control device connected to the serial port to the internal pull-down.

3.4 PPS

The CNT836P module provides a second pulse signal output interface (PPS). The PPS signal can provide the time service functions to the external system, and is effectively output after the module is properly positioned. Under the default situation, it outputs one pulse per second. If not in use, the signal can be unconnected.

3.5 RST_N

The CNT836P module provides 1 external reset signal input interface (RST_N), effective at low levels above 10ms. This signal interface can be unconnected if not in use.

3.6 GPIO

The CNT836P module reserves 2 general GPIO interfaces (GPIO1, GPIO2) for external antenna detection circuit. If not in use, this signal interface can be unconnected.

3.7 EXTINT

The CNT836P module provides 1 external interrupt signal input interface (EXTINT). It is not available in the default configuration, but can be customized.

4. Firmware Default configuration

4.1 Serial Port Settings (CFGPR1)			
Serial Port NO.	Parameter	Default configuration	Instructions
UART0	Baud rate	115200	Default baud rate 115,200 BPS
	Input protocol	2	
	Output protocol	1	NMEA
UART1	Baud rate	115200	Default baud rate 115,200 BPS
	Input protocol	2	
	Output protocol	0	Off
4.2 Message Settings (CFGMSG)			
Message Type	Parameter	Default configuration	Instructions
NMEA message	RMC	1	1Hz output
	VTG	1	1Hz output
	GGA	1	1Hz output
	GSA	1	1Hz output
	GSV	1	1Hz output
	GLL	1	1Hz output
	ZDA	0	Off

	GST	0	Off
	TXT	1	1Hz output
4.3 Satellite System Setup (CFGSYS)			
Navigation Type	Default configuration	Instructions	
NavSys	3	GPS + BDS dual system	
4.4 Navigation System Settings (CFGNAV)			
Parameter	Default Configuration	Instructions	
NavRate	1000	1000ms Positioning frequency	
minElev	5	Satellite cutoff Angle 5 degrees	

5. Module Installation and Initialization

5.1 Module installation instructions

- 1) The module must be fixed on the vehicle before powering on. Do not move the module during the power-on process.
- 2) The adaptive installation mode has no requirements on the installation direction;
- 3) Manual input installation Angle mode requires the installation error no more than 30 degrees, including the installation direction and input pitch Angle, roll Angle and heading Angle. (configured via the \$cfgrotat command).
- 4) This product is only for the vehicle (acceleration less than 2g) and requires a rigid body connection.

5.2 Initialization Instructions

The performance of the integrated navigation system is greatly affected by the initial state. In order to obtain better performance during the test, it is recommended to initialize the system as follows:

Manually enter the setup Angle mode:

- 1) Turn on and position in an open environment;
- 2) Drive at a speed of more than 40km/h in an open environment for more than 1 minute;
- 3) Complete at least two 90-degree turns in an open environment.

Adaptive mounting Angle mode:

- 1) Turn on and position in an open environment;
- 2) Stand still for more than five seconds;
- 3) Five or more straight line acceleration and deceleration in an open environment;
- 4) Drive at a speed of more than 40km/h in an open environment for more than 1 minute;
- 5) Complete at least two 90-degree turns in an open environment.

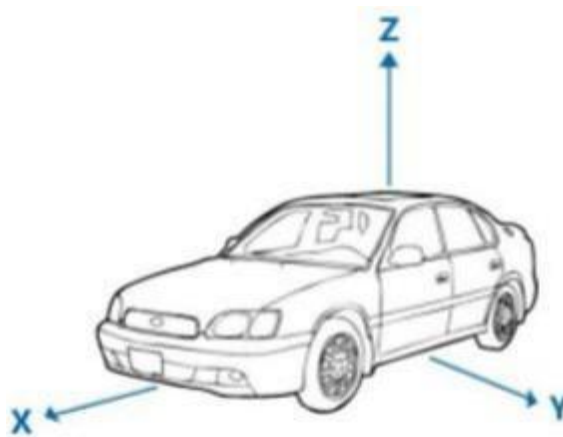

Figure 5-1 The module installation

6. Electrical Characteristics

6.1 Absolute Maximum						
Parameters	Symbols	Minimum value	Maximum	Units	Conditions	
Supply voltage (VCC)	Vcc	-0.5	3.6	V	--	
VCC Max ripple	Vrpp	0	50	mV	--	
Input pin voltage	Vin	-0.5	Vcc +0.2	V	--	
ESD	VESD(HBM)	--	2000	V	All pins	
MSD(MSL) level	Level 3					
6.2 Operating Conditions						
Parameters	Symbols	Minimum value	Recommended value	Maximum value	Units	Conditions
RTC supply voltage (V_BCKP)	Vrtc	2.0	3.0	3.6	V	--
RTC supplies current	Irtc	--	1000	1200	uA	Vcc = 3.3V
	Irtc	--	34	100	uA	Vcc = 0 V
Supply voltage (VCC)	Vcc	3.0	3.3	3.6	V	--
Supply current	Icc	50	53	--	mA	--
Peak current	Iccp	--	--	100	mA	Vcc = 3.3V
Input pin low	Vin_low	--	--	0.2 * Vcc	V	--
Input pin high	Vin_high	0.7 * Vcc	--	--	V	--
Output pin low	Vout_low	--	--	0.4	V	Iout= -8 mA

Output pin high	Vout_high	Vcc - 0.4	--	--	V	Iout = 8 mA
Antenna gain	Gant	5	--	40	dB	--
Receiver link noise factor	NFtot	--	3	--	dB	--
6.3 Working Environment						
Working temperature	-40°C~ +85°C					
Storage temperature	-40°C~ +85°C					

7. Mechanical specifications

The module construction dimensions are as follows:

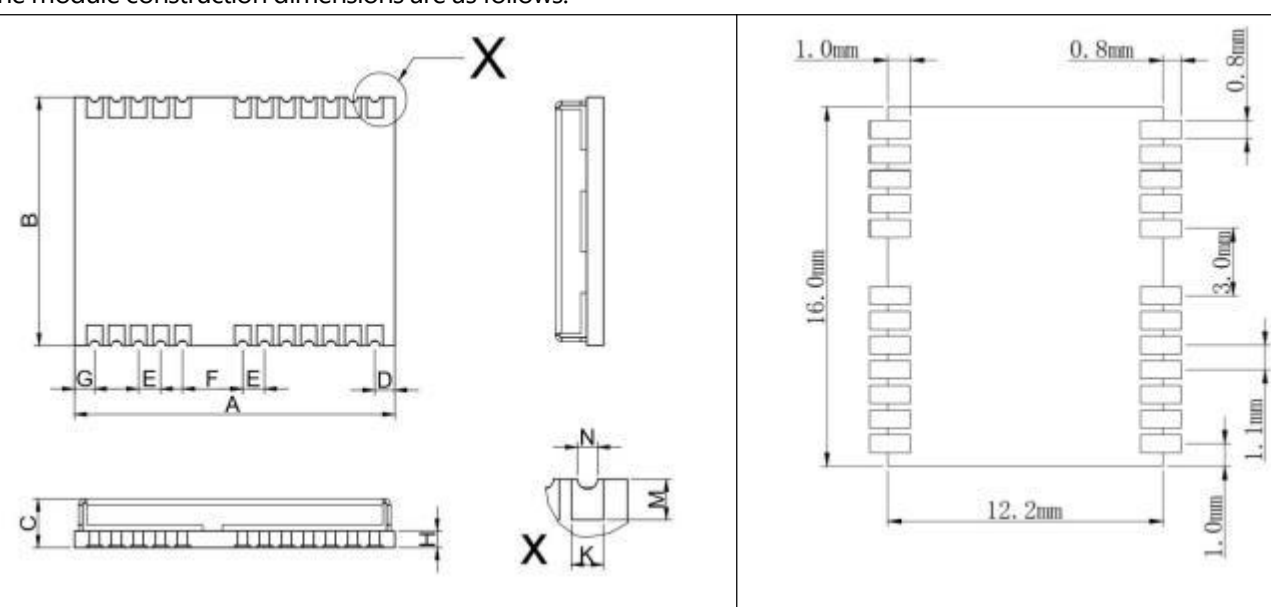

Figure 7-1 CNT836P dimensions and PCB package reference

Parameters	Value (mm)	Parameters	Value (mm)
------------	------------	------------	------------

A	16.0 +/- 0.3	G	1.0 +/- 0.1
B	12.2 +/- 0.1	H	0.82 +/- 0.08
C	2.36 +/- 0.2	K	0.8 +/- 0.1
D	1.0 +/- 0.1	N	0.5 +/- 0.1
E	1.1 ±0.1	M	0.9 +/- 0.1
F	3.0 +/- 0.1	- -	- -

8. Hardware Integration Guide

8.1 Minimum reference design

Figure 8-1 shows the schematic diagram of the minimum reference design for the CNT836P. External supply VDD3V3 and VBAT for power supply. The serial port of the module outputs NMEA0183 protocol data. The RF input is connected to the active antenna. The CNT836P feeds the active antenna through 9-pins VCC_RF, with recommended 3.3V feed voltage. If the RF is connected to the passive antenna, and the L1, R16, C8 all can be NC(unconnected). Pin 2 and pin 5 of the module serve as inputs to the external antenna detection circuit, and the external antenna detection circuit as shown in Figure 8-3. If the user does not need antenna detection function, module pin 2 and pin 5 can be unconnected.

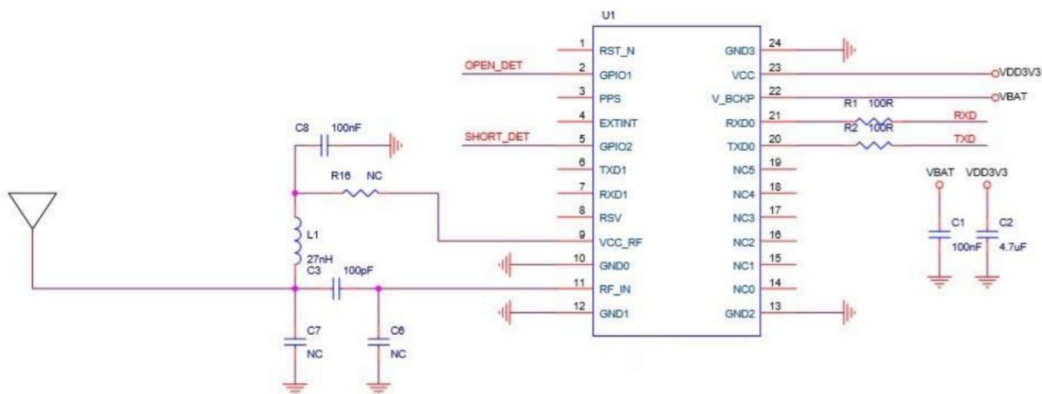

Figure 8-1 Minimum reference design of CNT836P

Note: Pin 22 of the module supplies power to the internal gyroscope, the pin must be connected, and requires an external battery. If there is no external battery, the pin needs to be shorted with 23-pin VCC, otherwise the gyroscope cannot work and the inertial navigation function will be abnormal.

8.2 Antenna Attentions

Antenna Signal

Modules support GNSS multimode active or passive antennas. For better performance, it is recommended to reserve 50 ohm impedance matching circuit outside the module. If the external passive antenna is connected, it is recommended to add one level LNA and SAW on the periphery.

Active antenna feed

If the active antenna is selected, the active antenna needs to be fed. The feed power can be provided by the terminal platform or the module VCC_RF.

As shown in Figure 8-2, the module VCC_RF is used to feed; R17 NC and R16 use 10R/0805 resistance; and the feed voltage standard/recommended value is 3.3V. The TVS tube of the RF input port can use the model LESD11LL5.0CT5 in the recommended reference design.

When using the external antenna feed, R16 NC, R17 use 10R/0805 resistance, at this time the feed voltage VCC_ANT will be depended on the user. When $VCC_ANT < 5V$, TVS can still use model LESD11LL5.0CT5 in the recommended reference design. When $VCC_ANT \geq 5V$, TVS selection should be adjusted according to the value of VCC_ANT, it is recommended that $VRWM > VCC_ANT + 1$, TVS junction capacitance should be less than 0.5pF.

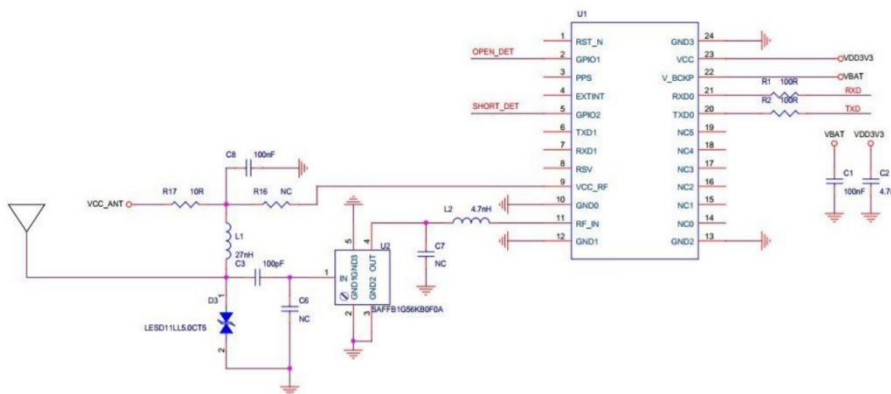

Figure 8-2 Reference design of the CNT836P module VCC_RF feed

Active Antenna Inspection

If the user needs the antenna detection function, it needs to cooperate with the peripheral detection circuit to achieve. Figure 8-3 shows the reference circuit for peripheral antenna detection. OPEN_DET connects to the module Pin 2 and SHORT_DET connects to the module Pin 5. As shown in the following table: Definition 1=High, 0=Low.

OPEN_DET	SHORT_DET	ANT STATE	State Instructions
0	0	OK	Antenna working normally
0	1	SHORT	Antenna short circuit
1	0	OPEN	Antenna open circuit
1	1	UNKNOWN	No peripheral antenna detection circuit

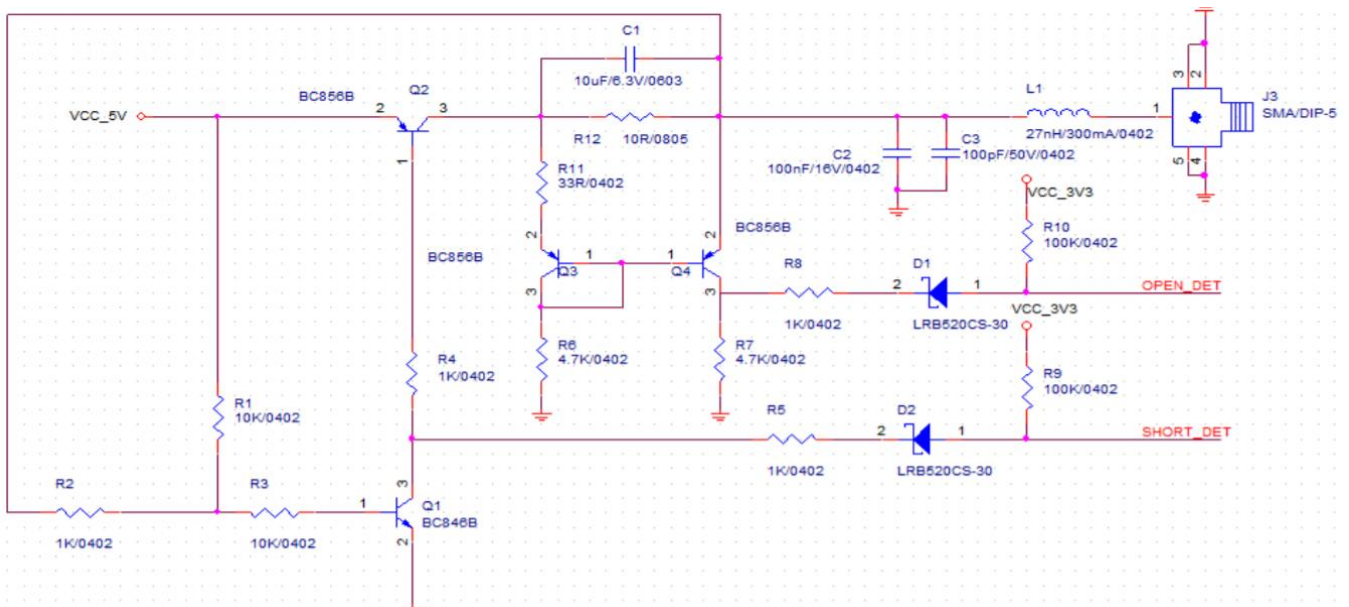

Figure 8-3 Reference circuit for CNT836P antenna detection

8.3 Power Supply Attentions:

To make the CNT836P to work normally, it is necessary to power the modules VCC and V_BCKP.

Attentions as below:

- 1) Provide a reliable power supply for the VCC pin. The power-on process of this power supply should be monotonically rising, and the power-on time should not exceed 10ms. During the power-on process, the waveform diagram should not present steps or back grooves. In addition, after the power supply is powered off, the level should be restored to zero.
- 2) It is recommended to use low-ripple LDO to power module VCC and V_BCKP, and the peak values (Max. and Mini.) of power ripple should not exceed 50mV. V_BCKP should be powered on no later than VCC.
- 3) It is recommended to widen the power supply line or use a split copper surface to transmit current, to avoid high-power and high-inductive devices such as magnetic coil.
- 4) Module 22 pin V_BCKP for the internal gyroscope power supply, must be connected. It is recommended that the pin be connected to the battery power supply to ensure the calibration data of the gyroscope can still be maintained after the system powered off. Otherwise, it needs to go through the initialization process described in chapter 5.2 to ensure the correctness of the inertial navigation results. If there is no external battery, please connect the pin with pin 23 VCC of the module. In this case, the initialization process described in section 5.2 must be performed for each power-on to ensure the correctness of the inertial navigation result.

8.4 Other Attentions

To make the CNT836P to work normally, relevant attentions as below:

- 1) Ground all GND pins of the module.
- 2) Connect the RF_IN signal to the antenna with the line maintaining a 50 ohm impedance match.
- 3) Ensure that the main device corresponds to the pin signal and baud rate of the CNT836P module.

To obtain good performance, the design should also pay special attention to the following:

- 1) Good performance needs to be stable and low ripple power supply to ensure. The peaks difference (Max. and Min.) of voltage ripple peak should not exceed 50mV.

- 2) Pay attention to the impedance matching of antenna line, as short and smooth as possible, avoid layer change and go acute Angle.
- 3) In order to ensure a good signal-to-noise ratio, ensure that the antenna has a good isolation from the electromagnetic radiation source, especially the electromagnetic radiation frequency band of 1559 ~1577MHz.
- 4) To avoid the module damage caused by static electricity, it is recommended to add an ESD protection device between the module and the external antenna input port.

Before using the module, ensure that the antenna is reliably connected. Do not plug or remove the antenna with electric heating.

Recommended ESD protection devices:

Device Model	Manufacturer	Junction Capacitance Parameters (pF)	VBR parameter (V)
LESD11LL5. 0 CT5G	Leshan Radio	Typ: 0.25	Min: 6
ESD9R3. 3ST5G	Onsemi	Typ: 0.5	Min: 4.6
ESD5V3U1U-02LS	Infineon	Typ: 0.4	Min:6

- 5) When layout PCB board, need to avoid to route directly under the CNT836P module.
- 6) This module is temperature sensitive equipment, drastic changes in temperature will cause its performance to be reduced, as far as possible away from high temperature air flow and high power heating device when in use.

9. Production requirements

Recommended furnace temperature curve for module welding as below:

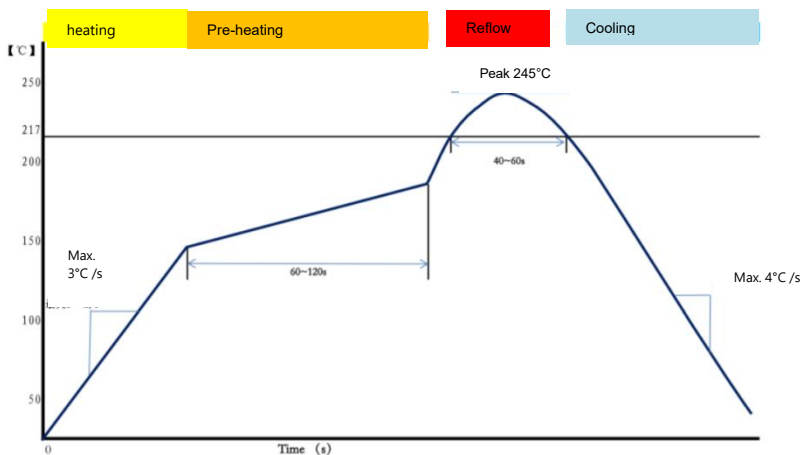

Figure 9-1 Recommended furnace temperature curve of CNT836P

The CNT836P module is lead-free, and the subsequent processing is lead-free welding by default. Our company has verified the module lead-free welding in the actual SMT production. The above recommended temperature settings takes lead-free welding as an example.

Notes:

- 1) To prevent the falling off of the module in the welding, please do not design to weld the module on the back of the board, that is, it is best not to experienced two secondary welding cycle.
- 2) The setting of welding temperature depends on many factors of the product factory, such as the nature of the main board, the type of solder paste, the thickness of the solder paste, etc. Please also refer to the relevant IPC standards and solder paste indicators.
- 3) Because the lead welding temperature is relatively low, if this welding method is used, please give priority to other components on the board.

10. Packaging and Transportation

10.1 Packing

The CNT836P module is packaged with anti-static and moisture-proof tape, and the tape is 1000pcs/ roll.

10.2 ESD Protection

The CNT836P module is an electrostatic sensitive device. Please pay attention to ESD protection during transportation and production. Do not randomly use your hand to touch or weld with a non-anti-static soldering iron to avoid the module damage.



11. Ordering Information

Part No.	MPQ	MOQ	Description
CNT836P	1000pcs	1000pcs	GNSS/INS (UDR) vehicle integrated navigation and positioning module

Shenzhen Simple Technology Electronics Co., LTD.



Focus on Precise Space-time, Assist in Smart Service Worldwide

Address: 23rd Floor, Xinlikang Building, QianHai Nanshan
District, Shenzhen City, Guangdong Province

Website: <https://xbteek.com>